



(12) **United States Patent**
Chao et al.

(10) **Patent No.:** **US 10,042,186 B2**
(45) **Date of Patent:** **Aug. 7, 2018**

(54) **ELECTRONIC EYEWEAR AND DISPLAY**

(56) **References Cited**

(71) Applicant: **IpVenture, Inc.**, Los Altos, CA (US)

U.S. PATENT DOCUMENTS

(72) Inventors: **David Chao**, Saratoga, CA (US);
Thomas A. Howell, Palo Alto, CA (US);
C. Douglass Thomas, Saratoga, CA (US);
Peter P. Tong, Mountain View, CA (US)

320,558 A 6/1885 Hull
669,949 A 3/1901 Underwood
1,255,265 A 2/1918 Zachara
1,917,745 A 7/1933 Weiss
(Continued)

(73) Assignee: **IpVenture, Inc.**, San Jose, CA (US)

FOREIGN PATENT DOCUMENTS

(*) Notice: Subject to any disclaimer, the term of this patent is extended or adjusted under 35 U.S.C. 154(b) by 0 days.

CA 2 487 391 12/2003
CN 88203065 11/1988
(Continued)

(21) Appl. No.: **14/211,491**

OTHER PUBLICATIONS

(22) Filed: **Mar. 14, 2014**

Restriction Requirement for U.S. Appl. No. 14/217,174, dated Mar. 28, 2016.

(65) **Prior Publication Data**

US 2014/0268017 A1 Sep. 18, 2014

(Continued)

Related U.S. Application Data

(60) Provisional application No. 61/792,702, filed on Mar. 15, 2013, provisional application No. 61/868,676, filed on Aug. 22, 2013.

Primary Examiner — William R Alexander
Assistant Examiner — Wen Huang

(51) **Int. Cl.**
G02C 11/00 (2006.01)

(57) **ABSTRACT**

(52) **U.S. Cl.**
CPC **G02C 11/10** (2013.01)

Novel eyewear apparatuses including a display are disclosed. In one embodiment, the apparatus also includes a frame. The frame includes a side region that includes an extendable arm. The first end of the extendable arm is attached to the frame and a second end of the extendable arm is attached to the display. The side region includes a cavity, where the extendable arm is adapted to retract back. The extendable arm is further adapted to extend out of the cavity and orient the display to be visually observable by a user of the eyewear apparatus. In another embodiment, the apparatus includes a concave reflective and an image source. The image source and the concave reflective surface are oriented to enable a user of the eyewear apparatus to view at least an image from the image source as reflected by the concave reflective surface.

(58) **Field of Classification Search**
CPC G02C 11/10; G02B 27/0176; G02B 2027/0138; G02B 2027/0178; G02B 2027/0159; G02B 2027/0181; G02B 27/0179
USPC 351/158; 345/7-8; 348/207.1, 62, 64
See application file for complete search history.

8 Claims, 10 Drawing Sheets

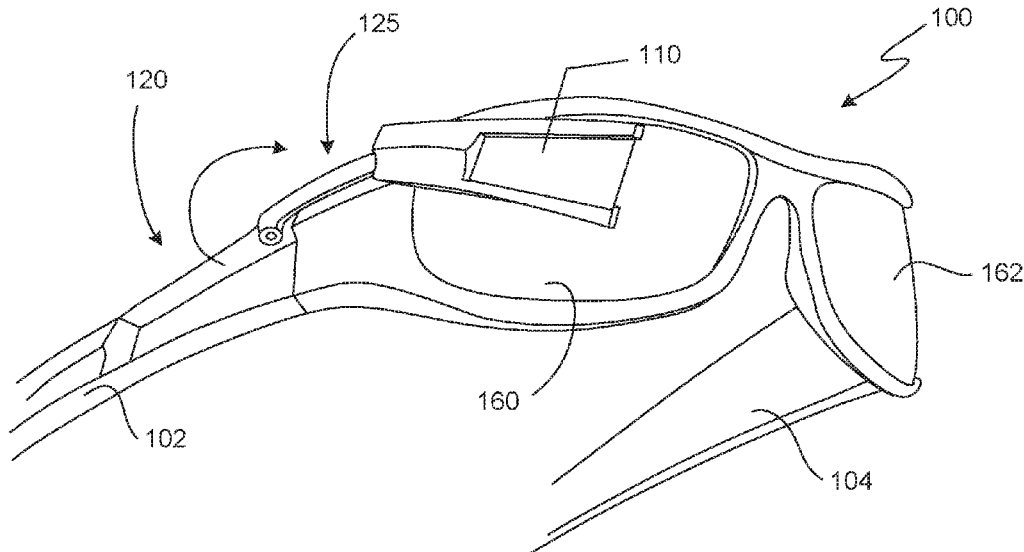

(56)

References Cited

U.S. PATENT DOCUMENTS

2,249,572	A	7/1941	Lieber	5,606,743	A	2/1997	Vogt et al.	
2,638,532	A	5/1953	Brady	5,608,808	A	3/1997	da Silva	
2,794,085	A	5/1957	De Angelis	5,634,201	A	5/1997	Mooring	
2,818,511	A	12/1957	Ullery et al.	5,671,035	A	9/1997	Barnes	
2,830,132	A	4/1958	Borg	5,686,727	A	11/1997	Reenstra et al.	
2,874,230	A	2/1959	Carlson	5,694,475	A	12/1997	Boyden	
2,904,670	A	9/1959	Calmes	5,715,323	A	2/1998	Walker	
3,060,308	A	10/1962	Fortuna	5,737,436	A	4/1998	Boyden et al.	
3,597,054	A	8/1971	Winter	5,818,381	A	10/1998	Williams	
3,710,115	A	1/1973	Jubb	5,835,185	A	11/1998	Kallman et al.	
3,858,001	A	12/1974	Bonne	5,900,720	A	5/1999	Kallman et al.	
3,883,701	A	5/1975	Delorenzo	5,903,395	A	5/1999	Rallison et al.	
4,165,487	A	8/1979	Corderman	5,941,837	A	8/1999	Amano et al.	
4,254,451	A	3/1981	Cochran, Jr.	5,946,071	A	8/1999	Feldman	
4,283,127	A	8/1981	Rosenwinkel et al.	5,949,516	A	9/1999	McCurdy	
4,322,585	A	3/1982	Liautaud	5,966,746	A	10/1999	Reedy et al.	
4,348,664	A	9/1982	Boschetti et al.	5,980,037	A	11/1999	Conway	
4,389,217	A	6/1983	Baughman et al.	5,988,812	A	11/1999	Wingate	
4,526,473	A	7/1985	Zahn, III	5,991,085	A	11/1999	Rallison et al.	
4,535,244	A	8/1985	Burnham	5,992,996	A	11/1999	Sawyer	
4,608,492	A	8/1986	Burnham	5,995,592	A	11/1999	Shirai et al.	
4,683,587	A	7/1987	Silverman	6,010,216	A	1/2000	Jesiek	
4,751,691	A	6/1988	Perera	6,013,919	A	1/2000	Schneider et al.	
4,757,714	A	7/1988	Purdy et al.	6,028,627	A	2/2000	Helmsderfer	
4,773,095	A	9/1988	Zwicker et al.	6,046,455	A	4/2000	Ribi et al.	
4,806,011	A	2/1989	Bettinger	6,060,321	A	5/2000	Hovorka	
4,822,160	A	4/1989	Tsai	6,061,580	A	5/2000	Altschul et al.	
4,822,161	A	4/1989	Jimmy	6,091,546	A	7/2000	Spitzer	
4,851,686	A	7/1989	Pearson	6,091,832	A	7/2000	Shurman et al.	
4,856,086	A	8/1989	McCullough	6,115,177	A	9/2000	Vossler	
4,859,047	A	8/1989	Badewitz	6,132,681	A	10/2000	Faran et al.	
4,882,769	A	11/1989	Gallimore	6,145,983	A	11/2000	Schiffer	
4,904,078	A	2/1990	Gorike	6,154,552	A	11/2000	Koroljow et al.	
4,942,629	A	7/1990	Stadlmann	6,176,576	B1	1/2001	Green et al.	
4,962,469	A	10/1990	Ono et al.	6,225,897	B1	5/2001	Doyle et al.	
4,967,268	A	10/1990	Lipton et al.	6,231,181	B1	5/2001	Swab	
4,985,632	A	1/1991	Bianco et al.	6,236,969	B1	5/2001	Ruppert et al.	
5,008,548	A	4/1991	Gat	6,243,578	B1	6/2001	Koike	
5,015,086	A	5/1991	Okaue et al.	6,259,367	B1	7/2001	Klein	
5,020,150	A	5/1991	Shannon	6,270,466	B1	8/2001	Weinstein et al.	
5,026,151	A	6/1991	Waltuck et al.	6,292,213	B1	9/2001	Jones	
5,036,311	A	7/1991	Moran et al.	6,292,685	B1	9/2001	Pompei	
5,050,150	A	9/1991	Ikeda	6,301,367	B1	10/2001	Boyden et al.	
5,064,410	A	11/1991	Frenkel et al.	6,307,526	B1	10/2001	Mann	
5,093,576	A	3/1992	Edmond et al.	6,343,858	B1	2/2002	Zelman	
5,106,179	A	4/1992	Kamaya et al.	6,349,001	B1	2/2002	Spitzer	
5,148,023	A	9/1992	Hayashi et al.	6,349,422	B1	2/2002	Schleger et al.	
5,151,600	A	9/1992	Black	6,409,335	B1*	6/2002	Lipawsky	G02C 5/06 351/124
5,161,250	A	11/1992	Ianna et al.	6,409,338	B1	6/2002	Jewell	
5,172,256	A	12/1992	Sethofer et al.	6,426,719	B1	7/2002	Nagareda et al.	
5,264,877	A	11/1993	Hussey	6,431,705	B1	8/2002	Linden	
5,306,917	A	4/1994	Black et al.	6,474,816	B2	11/2002	Butler et al.	
5,353,378	A	10/1994	Hoffman et al.	6,478,736	B1	11/2002	Mault	
5,359,370	A	10/1994	Mugnier	6,506,142	B2	1/2003	Itoh et al.	
5,359,444	A	10/1994	Piosenka et al.	6,511,175	B2	1/2003	Hay et al.	
5,367,345	A	11/1994	da Silva	6,513,532	B2	2/2003	Mault et al.	
5,379,464	A	1/1995	Schleger et al.	6,517,203	B1	2/2003	Blum et al.	
5,382,986	A	1/1995	Black et al.	6,539,336	B1	3/2003	Vock et al.	
5,394,005	A	2/1995	Brown et al.	6,542,081	B2	4/2003	Torch	
5,452,026	A	9/1995	Marcy, III	6,546,101	B1	4/2003	Murray et al.	
5,452,480	A	9/1995	Ryden	6,554,763	B1	4/2003	Amano et al.	
5,455,637	A	10/1995	Kallman et al.	6,582,075	B1	6/2003	Swab et al.	
5,455,640	A	10/1995	Gertsikov	6,619,799	B1	9/2003	Blum et al.	
5,457,751	A	10/1995	Such	6,629,076	B1	9/2003	Haken	
5,463,428	A	10/1995	Lipton et al.	6,729,726	B2	5/2004	Miller et al.	
5,500,532	A	3/1996	Kozicki	6,736,759	B1	5/2004	Stubbs et al.	
D369,167	S	4/1996	Hanson et al.	6,764,194	B1	7/2004	Cooper	
5,510,961	A	4/1996	Peng	6,769,767	B2	8/2004	Swab et al.	
5,513,384	A	4/1996	Brennan et al.	6,788,309	B1	9/2004	Swan et al.	
5,533,130	A	7/1996	Staton	6,792,401	B1	9/2004	Nigro et al.	
5,541,641	A	7/1996	Shimada	6,824,265	B1	11/2004	Harper	
5,581,090	A	12/1996	Goudjil	6,871,951	B2	3/2005	Blum et al.	
5,585,871	A	12/1996	Linden	6,879,930	B2	4/2005	Sinclair et al.	
5,589,398	A	12/1996	Krause et al.	6,912,386	B1	6/2005	Himberg et al.	
5,590,417	A	12/1996	Rydbeck	6,929,365	B2	8/2005	Swab et al.	
				6,932,090	B1	8/2005	Reschke et al.	
				6,947,219	B1	9/2005	Ou	
				7,004,582	B2	2/2006	Jannard et al.	

(56)	References Cited					
	U.S. PATENT DOCUMENTS					
7,013,009 B2	3/2006	Warren	2003/0067585 A1	4/2003	Miller et al.	
7,030,902 B2	4/2006	Jacobs	2003/0068057 A1	4/2003	Miller et al.	
7,031,667 B2	4/2006	Horiguchi	2003/0083591 A1	5/2003	Edwards et al.	
7,033,025 B2	4/2006	Winterbotham	2003/0214630 A1	11/2003	Winterbotham	
7,059,717 B2	6/2006	Bloch	2003/0226978 A1	12/2003	Ribi et al.	
7,073,905 B2	7/2006	Da Pra'	2004/0000733 A1	1/2004	Swab et al.	
7,079,876 B2	7/2006	Levy	2004/0029582 A1	2/2004	Swab et al.	
7,123,215 B2	10/2006	Nakada	2004/0059212 A1	3/2004	Abreu	
7,192,136 B2	3/2007	Howell et al.	2004/0063378 A1	4/2004	Nelson	
7,255,437 B2	8/2007	Howell et al.	2004/0096078 A1	5/2004	Lin	
7,265,358 B2	9/2007	Fontaine	2004/0100384 A1	5/2004	Chen et al.	
7,274,292 B2	9/2007	Velhal et al.	2004/0128737 A1	7/2004	Gesten	
7,289,767 B2	10/2007	Lai	2004/0150986 A1	8/2004	Chang	
7,312,699 B2	12/2007	Chormenky	2004/0156012 A1	8/2004	Jannard et al.	
7,331,666 B2	2/2008	Swab et al.	2004/0157649 A1	8/2004	Jannard et al.	
7,376,238 B1	5/2008	Rivas et al.	2004/0160571 A1	8/2004	Jannard	
7,380,936 B2	6/2008	Howell et al.	2004/0160572 A1	8/2004	Jannard	
7,401,918 B2	7/2008	Howell et al.	2004/0160573 A1	8/2004	Jannard et al.	
7,405,801 B2	7/2008	Jacobs	2004/0197002 A1	10/2004	Atsumi et al.	
7,429,965 B2	9/2008	Weiner	2004/0227219 A1	11/2004	Su	
7,438,409 B2	10/2008	Jordan	2005/0067580 A1	3/2005	Fontaine	
7,438,410 B1	10/2008	Howell et al.	2005/0078274 A1	4/2005	Howell et al.	
7,445,332 B2	11/2008	Jannard et al.	2005/0088365 A1	4/2005	Yamazaki et al.	
7,481,531 B2	1/2009	Howell et al.	2005/0201585 A1	9/2005	Jannard et al.	
7,500,746 B1	3/2009	Howell et al.	2005/0213026 A1	9/2005	Da Pra'	
7,500,747 B2	3/2009	Howell et al.	2005/0230596 A1	10/2005	Howell et al.	
7,512,414 B2	3/2009	Jannard et al.	2005/0238194 A1	10/2005	Chormenky	
7,527,374 B2	5/2009	Chou	2005/0239502 A1	10/2005	Swab et al.	
7,543,934 B2	6/2009	Howell et al.	2005/0248717 A1	11/2005	Howell et al.	
7,581,833 B2	9/2009	Howell et al.	2005/0248718 A1	11/2005	Howell et al.	
7,621,634 B2	11/2009	Howell et al.	2005/0248719 A1	11/2005	Howell et al.	
7,648,236 B1	1/2010	Dobson	2005/0264752 A1	12/2005	Howell et al.	
7,677,723 B2	3/2010	Howell et al.	2006/0001827 A1	1/2006	Howell et al.	
7,760,898 B2	7/2010	Howell et al.	2006/0003803 A1	1/2006	Thomas et al.	
7,771,046 B2	8/2010	Howell et al.	2006/0023158 A1	2/2006	Howell et al.	
7,792,552 B2	9/2010	Thomas et al.	2006/0034478 A1	2/2006	Davenport	
7,806,525 B2	10/2010	Howell et al.	2006/0107822 A1	5/2006	Bowen	
7,922,321 B2	4/2011	Howell et al.	2006/0132382 A1	6/2006	Jannard	
7,976,159 B2	7/2011	Jacobs et al.	2007/0030442 A1	2/2007	Howell et al.	
8,109,629 B2	2/2012	Howell et al.	2007/0035830 A1	2/2007	Matveev et al.	
8,142,015 B2	3/2012	Paolino	2007/0046887 A1	3/2007	Howell et al.	
8,337,013 B2	12/2012	Howell et al.	2007/0055888 A1	3/2007	Miller et al.	
8,430,507 B2	4/2013	Howell et al.	2007/0098192 A1	5/2007	Sipkema	
8,434,863 B2	5/2013	Howell et al.	2007/0109491 A1	5/2007	Howell et al.	
8,465,151 B2	6/2013	Howell et al.	2007/0186330 A1	8/2007	Howell et al.	
8,485,661 B2	7/2013	Yoo et al.	2007/0200927 A1	8/2007	Krenik	
8,500,271 B2	8/2013	Howell et al.	2007/0208531 A1	9/2007	Darley et al.	
8,770,742 B2	7/2014	Howell et al.	2007/0270663 A1	11/2007	Ng et al.	
8,905,542 B2	12/2014	Howell et al.	2007/0271065 A1	11/2007	Gupta et al.	
9,033,493 B2	5/2015	Howell et al.	2007/0271116 A1	11/2007	Wysocki et al.	
9,244,292 B2	1/2016	Swab et al.	2007/0271387 A1	11/2007	Lydon et al.	
9,405,135 B2	8/2016	Sweis et al.	2007/0279584 A1	12/2007	Howell et al.	
9,488,520 B2	11/2016	Howell et al.	2008/0062338 A1	3/2008	Herzog et al.	
9,547,184 B2	1/2017	Howell et al.	2008/0068559 A1	3/2008	Howell et al.	
9,690,121 B2	6/2017	Howell et al.	2008/0144854 A1	6/2008	Abreu	
2001/0005230 A1	6/2001	Ishikawa	2008/0151175 A1	6/2008	Gross	
2001/0028309 A1	10/2001	Torch	2008/0151179 A1	6/2008	Howell et al.	
2001/0050754 A1	12/2001	Hay et al.	2008/0158506 A1*	7/2008	Fuziak G02B 27/0172 351/158	
2002/0017997 A1	2/2002	Felkowitz	2008/0218684 A1	9/2008	Howell et al.	
2002/0021407 A1	2/2002	Elliott	2008/0262392 A1	10/2008	Ananny et al.	
2002/0081982 A1	6/2002	Schwartz et al.	2008/0278678 A1	11/2008	Howell et al.	
2002/0084990 A1	7/2002	Peterson, III	2009/0059159 A1	3/2009	Howell et al.	
2002/0089639 A1	7/2002	Starnier et al.	2009/0073375 A1	3/2009	Nakada	
2002/0090103 A1	7/2002	Calisto, Jr.	2009/0141233 A1	6/2009	Howell et al.	
2002/0098877 A1	7/2002	Glezerman	2009/0147215 A1	6/2009	Howell et al.	
2002/0101568 A1	8/2002	Eberl et al.	2009/0156128 A1	6/2009	Franson et al.	
2002/0109600 A1	8/2002	Mault et al.	2009/0251661 A1*	10/2009	Fuziak, Jr. G02B 27/0172 351/158	
2002/0140899 A1	10/2002	Blum et al.	2009/0296044 A1	12/2009	Howell et al.	
2002/0159023 A1	10/2002	Swab	2010/0061579 A1	3/2010	Rickards et al.	
2002/0197961 A1	12/2002	Warren	2010/0079356 A1	4/2010	Hoellwarth	
2003/0018274 A1	1/2003	Takahashi et al.	2010/0110368 A1	5/2010	Chaum	
2003/0022690 A1	1/2003	Beyda et al.	2010/0245754 A1*	9/2010	Matsumoto G02B 27/0176 351/158	
2003/0032449 A1	2/2003	Giobbi	2010/0296045 A1	11/2010	Agnoli et al.	
2003/0062046 A1	4/2003	Wiesmann et al.	2010/0309426 A1	12/2010	Howell et al.	
2003/0065257 A1	4/2003	Mault et al.	2011/0102734 A1	5/2011	Howell et al.	
			2011/0164122 A1	7/2011	Hardacker	

(56)

References Cited

U.S. PATENT DOCUMENTS

2011/0187990	A1	8/2011	Howell et al.	
2011/0241976	A1	10/2011	Boger et al.	
2011/0273365	A1*	11/2011	West	G02B 27/0176 345/8
2012/0033061	A1	2/2012	Ko et al.	
2012/0050668	A1	3/2012	Howell et al.	
2012/0133885	A1	5/2012	Howell et al.	
2013/0072828	A1	3/2013	Sweis et al.	
2013/0201440	A1	8/2013	Howell et al.	
2013/0308089	A1	11/2013	Howell et al.	
2014/0132913	A1	5/2014	Sweis et al.	
2014/0176902	A1	6/2014	Sweis et al.	
2014/0198293	A1	7/2014	Sweis et al.	
2014/0268008	A1	9/2014	Howell et al.	
2014/0268013	A1	9/2014	Howell et al.	
2014/0268017	A1	9/2014	Sweis et al.	
2014/0361185	A1	12/2014	Howell et al.	
2015/0085245	A1	3/2015	Howell et al.	
2015/0230988	A1	8/2015	Chao et al.	
2015/0253590	A1	9/2015	Howell et al.	
2016/0246075	A9	8/2016	Howell et al.	
2016/0302992	A1	10/2016	Sweis et al.	
2017/0074721	A1	3/2017	Howell et al.	
2017/0090219	A1	3/2017	Howell et al.	
2017/0131575	A1	5/2017	Howell et al.	
2017/0146829	A1	5/2017	Howell et al.	

FOREIGN PATENT DOCUMENTS

CN	89214222.7	3/1990
CN	90208199.3	11/1990
DE	10123226 A1	11/2002
EP	1134491 A2	9/2001
FR	2530039 A1	1/1984
GB	1467982	3/1977
JP	58-113912	7/1983
JP	58-113914	7/1983
JP	02-181722	7/1990
JP	09-017204	1/1997
JP	10-161072	6/1998
JP	2000-039595	2/2000
JP	2002 341059 A	11/2002
JP	2005-151292	6/2005
TW	484711	6/2001
WO	WO 97/12205 A1	4/1997
WO	WO 99/50706 A1	10/1999
WO	WO 01/06298 A1	1/2001
WO	WO 02/06881 A2	1/2002
WO	WO 03/069394 A1	8/2003
WO	WO 03/100368 A1	12/2003
WO	WO 04/012477 A2	2/2004
WO	WO 04/025554 A1	3/2004
WO	WO 10/0141514 A2	12/2010

OTHER PUBLICATIONS

Office Action for U.S. Appl. No. 14/217,174, dated Jul. 28, 2016.
 Election Requirement for U.S. Appl. No. 14/211,491, dated Jul. 16, 2015.
 Office Action for U.S. Appl. No. 14/211,491, dated Oct. 19, 2015.
 Office Action for U.S. Appl. No. 14/211,491, dated Feb. 23, 2016.
 Notice of Allowance for U.S. Appl. No. 14/211,491, dated Nov. 9, 2016.
 “±1.5g Dual Axis Micromachined Accelerometer”, Freescale Semiconductor, Inc., Motorola Semiconductor Technical Data, MMA6260Q, Jun. 2004, pp. 1-7.
 “APA Announces Shipment of the SunUV™ Personal UV Monitor”, Press Release, Nov. 7, 2003, pp. 1-3.
 “Camera Specs Take Candid Snaps”, BBC News, Sep. 18, 2003, pp. 1-3.
 “Cardo Wireless Attaching Clips and Wearing Headset,” Cardo Systems, Inc., <http://www.cardowireless.com/clips.php>, downloaded Nov. 27, 2004, pp. 1-3.

“Environmental Health Criteria 14: Ultraviolet Radiation”, International Programme on Chemical Safety, World Health Organization Geneva, 1979 <http://www.ichem.org>, pp. 1-102.
 “Exclusive Media Event Marks Debut of Oakley Thump: World’s First Digital Audio Eyewear”, Oakley Investor Relations, Press Release, Nov. 15, 2004, pp. 1-2.
 “Eyetop”, Product-Features, eyetop eyewear, eyetop belt worn, <http://www.eyetop.net/products/eyetop/features.asp>, downloaded Nov. 6, 2003, pp. 1-2.
 “Heart Rate Monitors”, <http://www.healthgoods.com>, downloaded Dec. 4, 2004.
 “How is the UV Index Calculated”, SunWise Program, U.S. Environmental Protection Agency, <http://www.epa.gov/sunwise/uvcalc.html>, downloaded Oct. 14, 2004, pp. 1-2.
 “Industrial UV Measurements”, APA Optics, Inc., <http://www.apaoptics.com/uv/>, downloaded Jul. 12, 2004, p. 1.
 “Motorola and Oakley Introduce First Bluetooth Sunglasses-Cutting Edge RAZRWire Line Offers Consumers On-The-Go Connections”, Motorola Mediacenter-Press Release, Feb. 14, 2005, pp. 1-2.
 “Oakley Thump: Sunglasses Meet MP3 Player”, with image, <http://news.designtechnica.com/article4665.html>, Jul. 13, 2004.
 “Personal UV monitor,” Optics.org, <http://optics.org/articles/news/6/6/7/1> (downloaded Dec. 20, 2003), Jun. 9, 2000, pp. 1-2.
 “SafeSun Personal Ultraviolet Light Meter”, <http://healthchecksyste.ms.com/safesun.htm>, downloaded Jul. 12, 2004, pp. 1-4.
 “SafeSun Personal UV Meter”, Introduction, Optix Tech Inc., <http://www.safesun.com>, downloaded Feb. 5, 2004, pp. 1-2.
 SafeSun Personal UV Meter, features, Optix Tech Inc., <http://www.safesun.com/features.html>, downloaded May 1, 2004, pp. 1-2.
 “Sharper Image—The FM Pedometer”, e-Corporate Gifts.com, <http://www.e-corporategifts.com/sr353.html>, downloaded Jan. 22, 2005, pp. 1-2.
 “Sun UV™ Personal UV Monitor”, APA Optics, Inc., <http://www.apaoptics.com/sunuv/uvfacts.html>, downloaded Dec. 20, 2003, pp. 1-3.
 “Ultraviolet Light and Sunglasses”, Oberon’s Frequently Asked Questions, <http://www.oberoncompany.com/OBEnglish/FAQUV.html>, downloaded Feb. 5, 2004, pp. 1-2.
 “Ultraviolet Light Sensor”, Barrett & Associates Engineering, http://www.barrettengineering.com/project_uv.htm, downloaded Feb. 5, 2004, pp. 1-3.
 “Ultraviolet Radiation (UVR)”, Forum North, Ontario Ministry of Labour, <http://www3.mb.sympatico.ca/~ericc/ULTRAVIOLET%20RADIATION.htm>, downloaded Feb. 5, 2004, pp. 1-6.
 “What Are Gripples?”, Gripping Eyewear, Inc., <http://www.grippingeyewear.com/whatare.html>, downloaded Nov. 2, 2005.
 “With Racing Heart”, Skaloud et al., GPS World, Oct. 1, 2001, <http://www.gpsworld.com/gpsworld/content/printContentPopup.jsp?id=1805>, pp. 1-5.
 Abrisa Product Information: Cold Mirrors, Abrisa, Jun. 2001, p. 1.
 Abrisa Product Information: Commercial Hot Mirror, Abrisa, Jun. 2001, p. 1.
 Alps Spectacle, Air Conduction Glass, Bone Conduction Glass, <http://www.alps-inter.com/spec.htm>, downloaded Dec. 10, 2003, pp. 1-2.
 Altimeter and Compass Watches, <http://store.yahoo.com/snowshack/altimeter-watches.html>, downloaded May 3, 2004, pp. 1-2.
 Pediatric Eye Disease Group, “Randomized Trial of Treatment of Amblyopia in Children Aged 7 to 17 Years,” Roy W. Beck, M.D., Ph.D. Section Ed., Originally Published and Reprinted from Arch Ophthalmol, v. 123, Apr. 2005, pp. 437-447, <http://archophth.jamanetwork.com/> by a new England College of Optometry User on Dec. 20, 2012.
 Bone Conduction Headgear HG16 Series, “Voiceducer,” <http://www.temco-j.co.jp/html/English/HG16.html>, downloaded Dec. 10, 2003, pp. 1-3.
 Carnoy, David, “The Ultimate MP3 Player for Athletes? Could be.”, CNET Reviews, May 14, 2004, pp. 1-4.
 Clifford, Michelle A., “Accelerometers Jump into the Consumer Goods Market”, Sensors Online, <http://www.sensorsmag.com>, Aug. 2004.

(56)

References Cited

OTHER PUBLICATIONS

- Comfees.com, Adjustable Sports Band Style No. 1243, <http://shop.store.yahoo.com/comfees/adspportbansty.html>, downloaded Apr. 18, 2003, pp. 1-2.
- Cool Last Minute Gift Ideas! UltimateFatBurner Reviews and Articles, <http://www.ultimatefatburner.com/gift-ideas.html>, downloaded May 10, 2005, pp. 1-3.
- Dickie et al. "Eye Contact Sensing Glasses for Attention-Sensitive Wearable Video Blogging," Human Media Lab, Queen's University, Kingston, ON K7L 3N6, Canada, est. Apr. 2004, pp. 1-2.
- Dixen, Brian, "ear-catching", Superstest, Mobil, Apr. 2003 (estimated), pp. 37-41.
- Global Solar UV Index, A Practical Guide, World Health Organization, 2002, pp. 1-28.
- Grobart, Sam, "Digit-Sizing Your Computer Data", News Article, Sep. 2004, p. 1.
- Holmes, JM et al. "A randomized trial of prescribed patching regimens for treatment of severe amblyopia in children." *Ophthalmology*, v. 110, Iss.11, Nov. 2003, pp. 2075-2087.
- Life Monitor V1.1, Rhusoft Technologies Inc., <http://www.rhusoft.com/lifemonitor/>, Mar. 1, 2003, pp. 1-6.
- Manes, Stephen, "Xtreme Cam", Forbes Magazine, Sep. 5, 2005, p. 96.
- Mio, PhysiCal, <http://www.gophysical.com/>, downloaded Jan. 27, 2004, 5 pages.
- Monitoring Athletes Performance—2002 Winter Olympic News from KSL, Jan. 23, 2002, <http://2002.ksl.com/news-3885i>, pp. 1-3.
- Niwa, "UV Index Information", <http://www.niwa.cri.nz/services/uvzone/uvi-info>, downloaded Jul. 15, 2004, pp. 1-2.
- NuVision 60GX Steroscopic Wireless Glasses, Product Information, NuVision by MacNaughton, c. 1997, MacNaughton, Inc., pp. 1-2.
- Pärkkä, Juha, et al., "A Wireless Wellness Monitor for Personal Weight Management", VTT Information Technology, Tampere, Finland, Nov. 2000, p. 1.
- Pedometer, Model HJ-112, Omron Instruction Manual, Omron Healthcare, Inc., 2003, pp. 1-27.
- PNY Announces Executive Attaché USB 2.0 Flash Drive and Pen Series, Press Release, PNY Technologies, Las Vegas, Jan. 8, 2004, pp. 1-2.
- PNY Technologies, "Executive Attaché" <http://www.pny.com/products/flash/execattache.asp> downloaded Nov. 16, 2005.
- Polar WM41 and 42 weight management monitor, http://www.simplysports/polar/weight_management/wm41-42.htm, downloaded Jan. 28, 2004, pp. 1-3.
- Questions Answers, Pedometer.com, <http://www.pedometer.com>, downloaded May 5, 2005.
- RazrWire, copyright Motorola, Inc., Jul. 2005, 1 page.
- Repka MX et al. "A randomized trial of patching regimens for treatment of moderate amblyopia in children." *Arch Ophthalmology* v. 121, No. 5, May 2003, pp. 603-611.
- SafeSun Personal UV Meter, Scientific Data, Optix Tech Inc., <http://www.safesun.com/scientific.html>, downloaded May 1, 2004, pp. 1-3.
- SafeSun Sensor, User's Manual, Optix Tech Inc., Jun. 1998, 2 pages.
- SafeSun, Personal UV Meter, "Technical Specifications," Optix Tech Inc., <http://www.safesun.com/technical.html>, downloaded Jul. 12, 2004, pp. 1-2.
- SafeSun, Personal UV Meter, Experiments, Optix Tech Inc., <http://www.safesun.com/experiments.html>, downloaded Feb. 5, 2004, pp. 1-2.
- Shades of Fun, Blinking Light Glasses, <http://www.shadesoffun.com/Nov/Novpgs-14.html>, downloaded Jul. 9, 2005, pp. 1-4.
- SportLine Fitness Pedometer-Model 360, UltimateFatBurner Superstore, http://www.ultimatefatburner-store.com/ac_004.html, downloaded May 10, 2005, pp. 1-2.
- Steele, Bonnie G. et al., "Bodies in motion: Monitoring daily activity and exercise with motion sensors in people with chronic pulmonary disease", VA Research & Development, Journal of Rehabilitation Research & Development, vol. 40, No. 5, Sep./Oct. 2003, Supplement 2, pp. 45-58.
- Stevens, Kathy, "Should I Use a Pedometer When I Walk?", Healthon/WebMD, Apr. 14, 2000.
- Sundgot, Jørgen "2nd-gen Motorola Bluetooth headset", InfoSync World, Mar. 1, 2003, <http://www.infosync.no/news/2002/n/2841.html>, pp. 1-2.
- SunSensors, Segan Industries, Inc., <http://www.segan-ind.com/sunsensor.htm>, downloaded Feb. 5, 2004, pp. 1-3.
- SunUV™, Personal UV Monitor User's Guide, APA Optics, Inc., 2003 pp. 1-52.
- SunUV™, Personal UV Monitor, APA Optics, Inc., <http://www.apaoptics.com/sunuv/models.html>, downloaded Dec. 20, 2003.
- Talking Pedometer, Sportline, Inc., Jun. 2001 (*Possibly earlier*), 1 page.
- The unofficial ELSA 3D Revelator page, Dec. 30, 1999, pp. 1-15.
- Top Silicon PIN Photodiode, PD93-21C, Technical Data Sheet, Everlight Electronics Co., Ltd., 2004, pp. 1-9.
- UV Light Meter, UVA and UVB measurement, UV-340, Instruction Manual, Lutron, Jun. 2003 (*estimated*), pp. 1-5.
- UV-Smart, UVA/B Monitor, Model EC-960-PW, Instruction Manual, Tanita Corporation of America, Inc., downloaded Nov. 16, 2001.
- Vitaminder Personal Carb Counter, <http://www.auravita.com/products/AURA/ORBU11420.asp>. Downloaded Nov. 15, 2005, pp. 1-4.
- Wallace DK et al. "A randomized trial to evaluate 2 hours of daily patching for strabismic and anisometropic amblyopia in children." *Ophthalmology* v. 113, No. 6, Jun. 2006, pp. 904-912.
- Yamada et al. "Development of an eye-movement analyser possessing functions for wireless transmission and autocalibration," Med. Biol. Eng. Comput., No. 28, v.4, Jul. 28, 1990, <http://link.springer.com/article/10.1007%2FBF02446149?LI=true>, pp. 1-2.
- Office Action for U.S. Appl. No. 14/072,784, dated Jul. 27, 2015.
- Office Action for U.S. Appl. No. 14/072,784, dated Oct. 29, 2015.
- Notice of Allowance for U.S. Appl. No. 14/072,784, dated Jan. 14, 2016.
- Notice of Allowance for U.S. Appl. No. 14/072,784, dated Apr. 7, 2016.
- Office Action for U.S. Appl. No. 15/193,155, dated Sep. 26, 2016.
- Office Action for U.S. Appl. No. 15/193,155, dated Jun. 8, 2017.
- Office Action for U.S. Appl. No. 14/190,352, dated Oct. 26, 2016.
- Office Action for U.S. Appl. No. 14/190,352, dated May 4, 2017.
- Office Action for U.S. Appl. No. 14/703,875, dated Oct. 5, 2016.
- Office Action for U.S. Appl. No. 14/703,875, dated May 17, 2017.
- Office Action for U.S. Appl. No. 14/217,174, dated Feb. 10, 2017.
- Office Action for U.S. Appl. No. 14/703,875, dated Apr. 12, 2018.

* cited by examiner

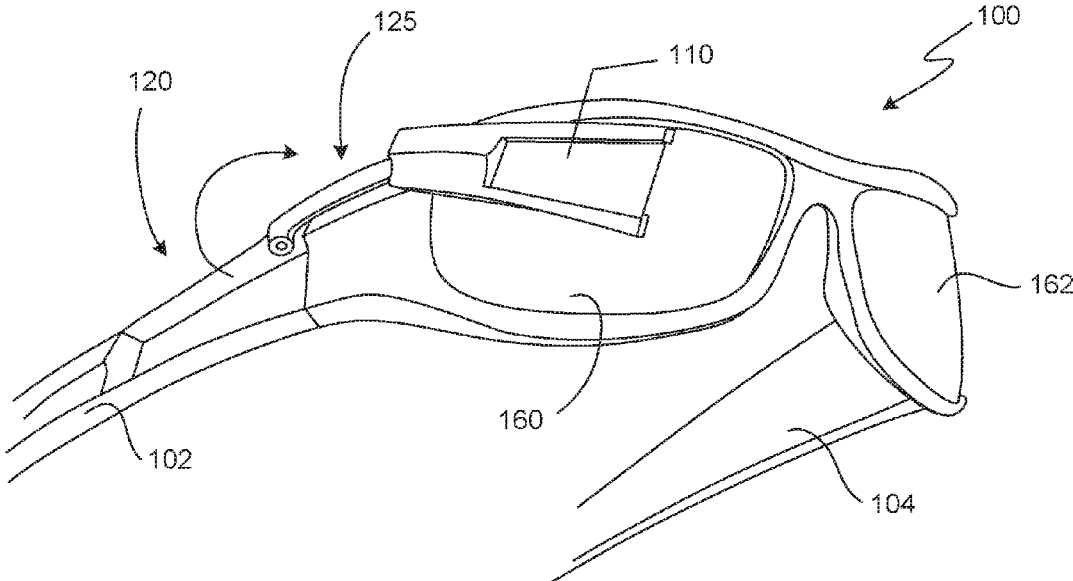

FIG. 1

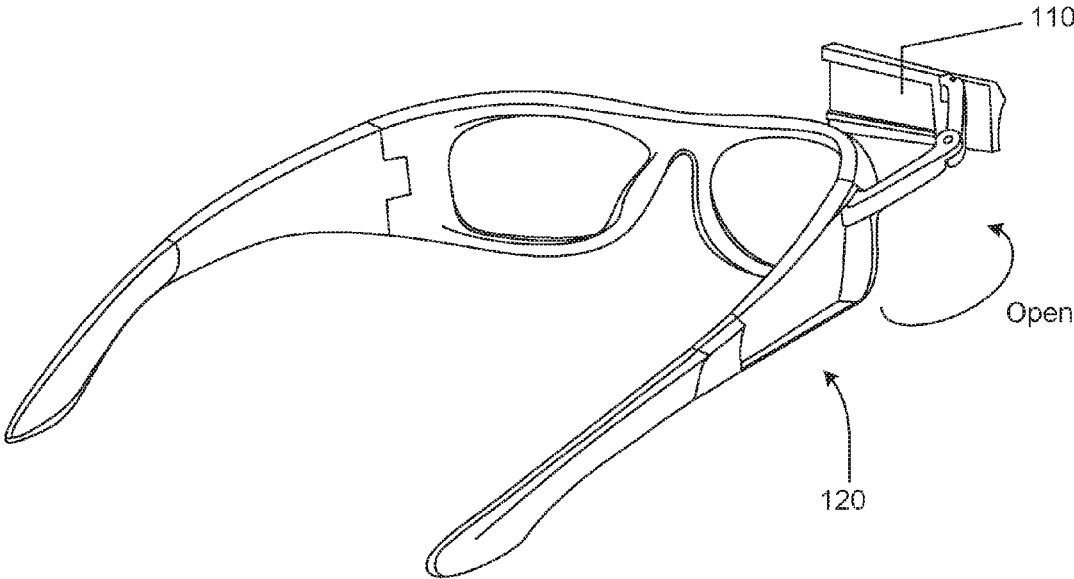

FIG. 2

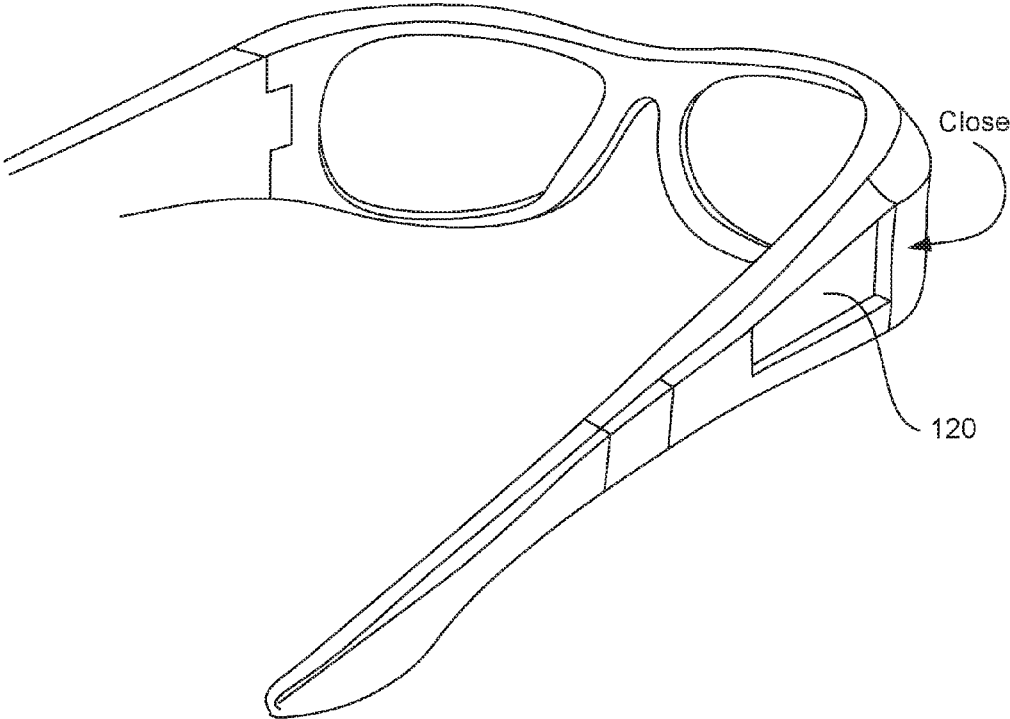

FIG. 3

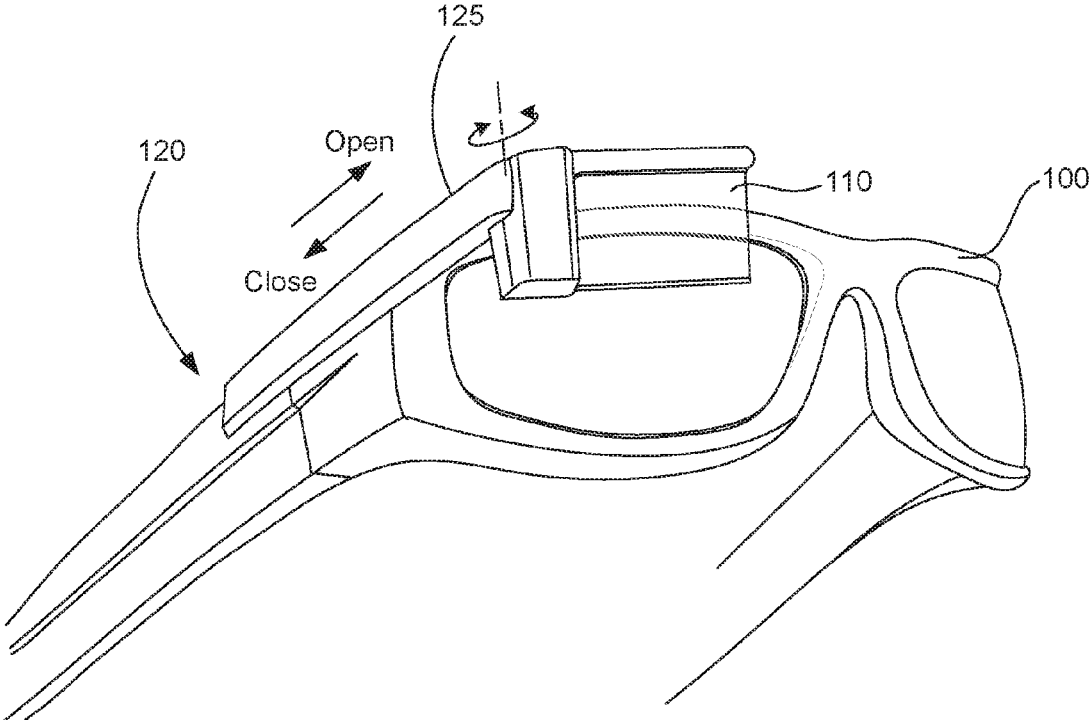

FIG. 4

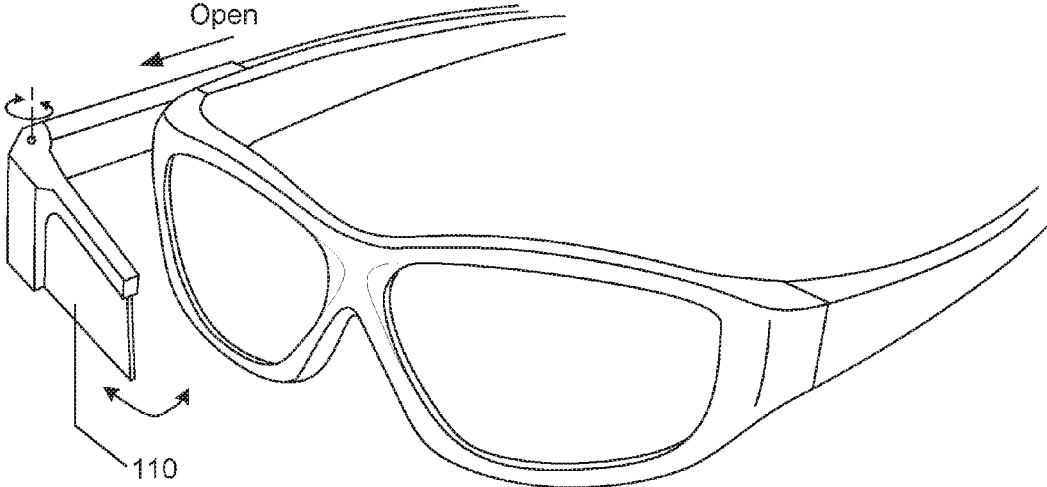

FIG. 5

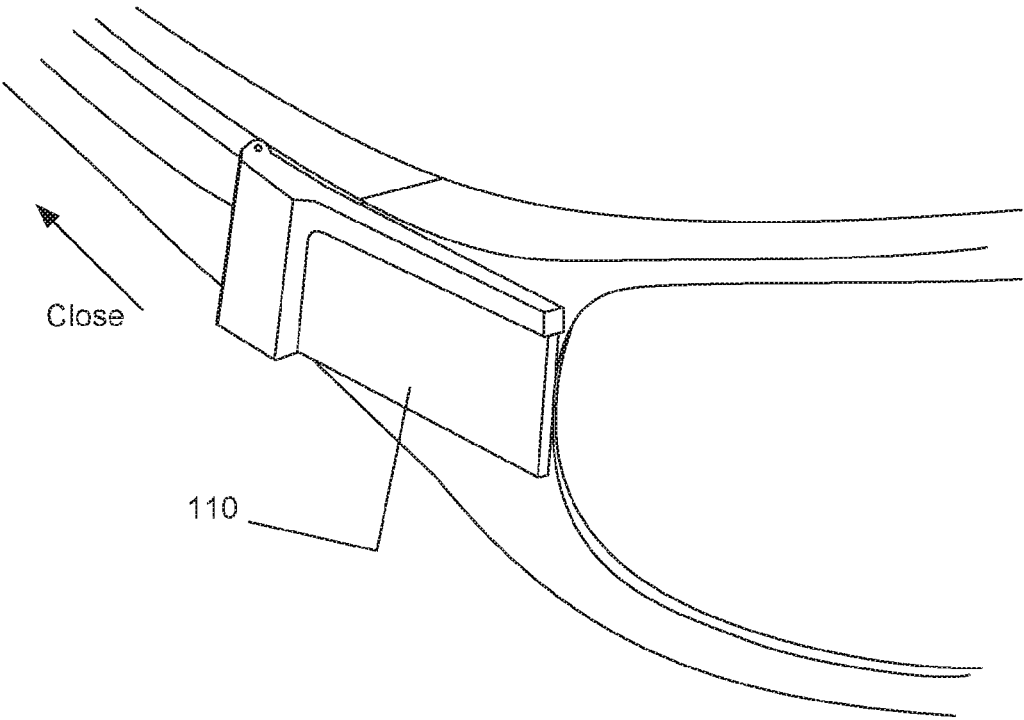

FIG. 6

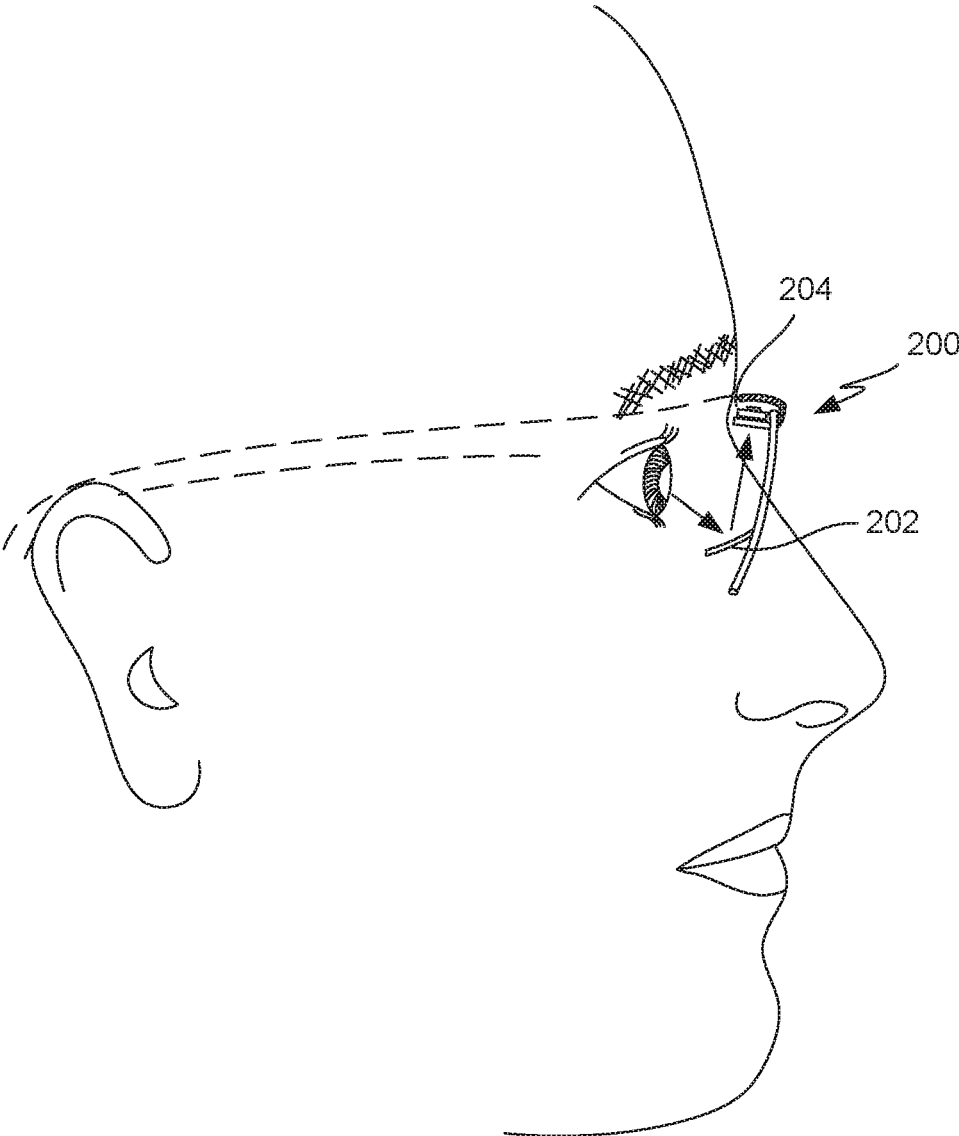

FIG. 7

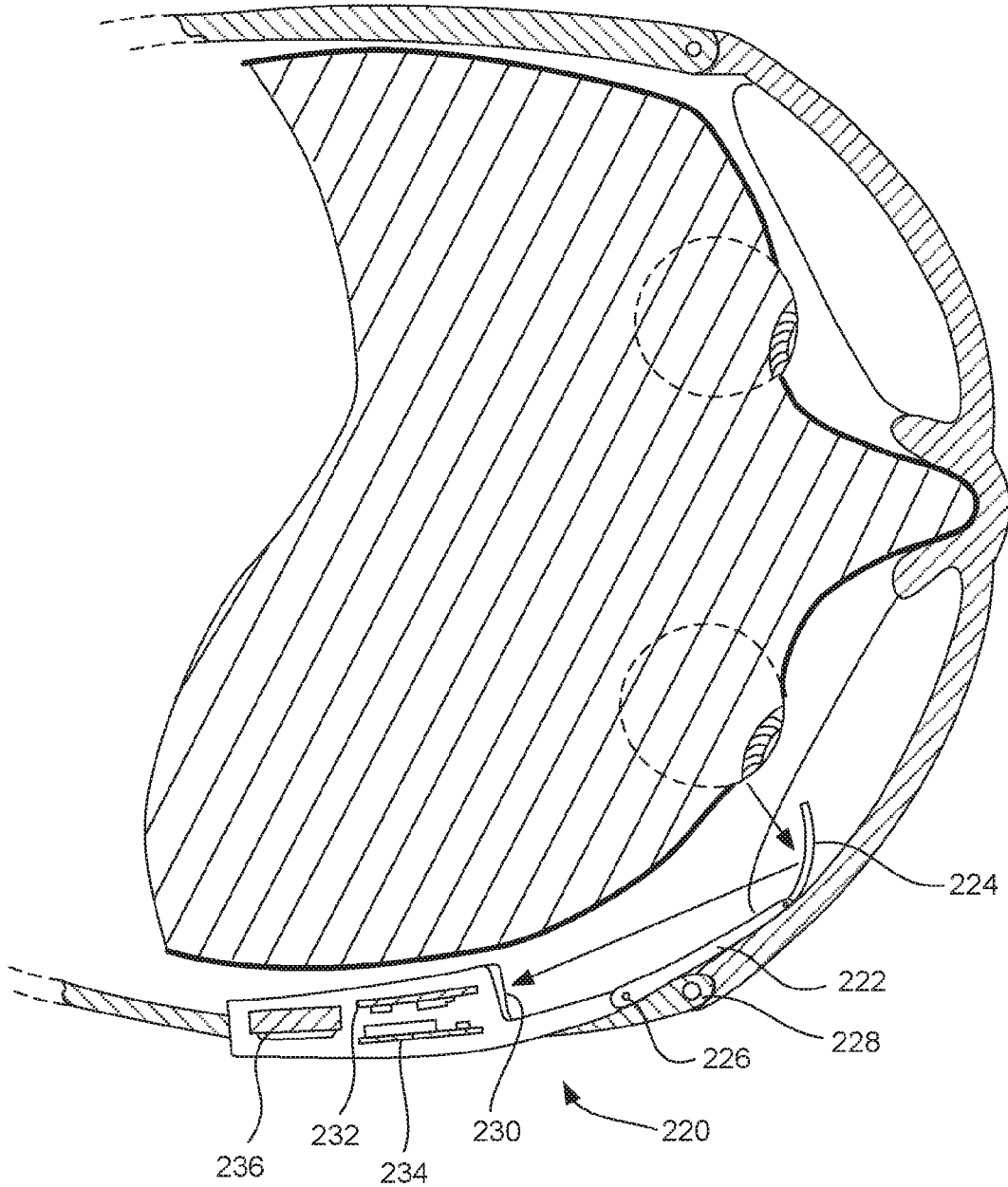

FIG. 8A

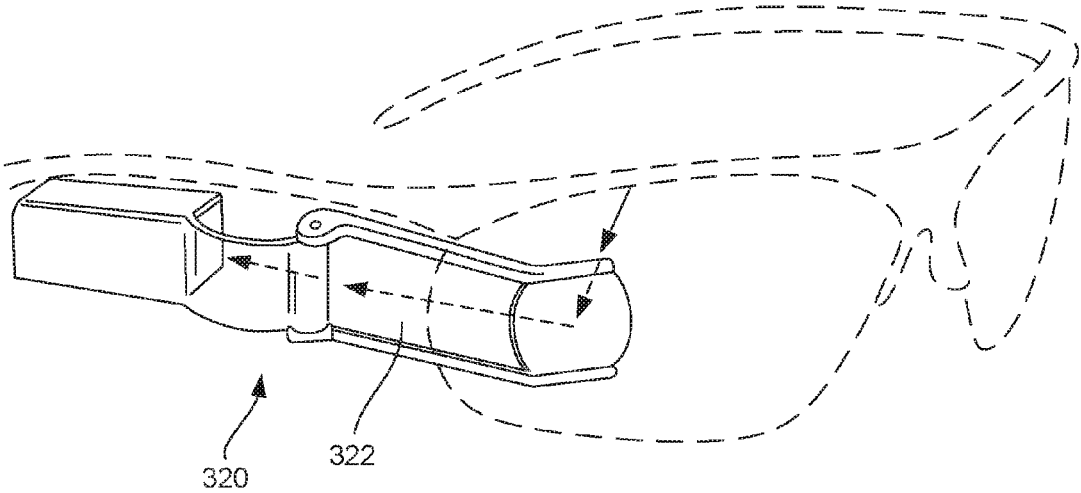

FIG. 8B

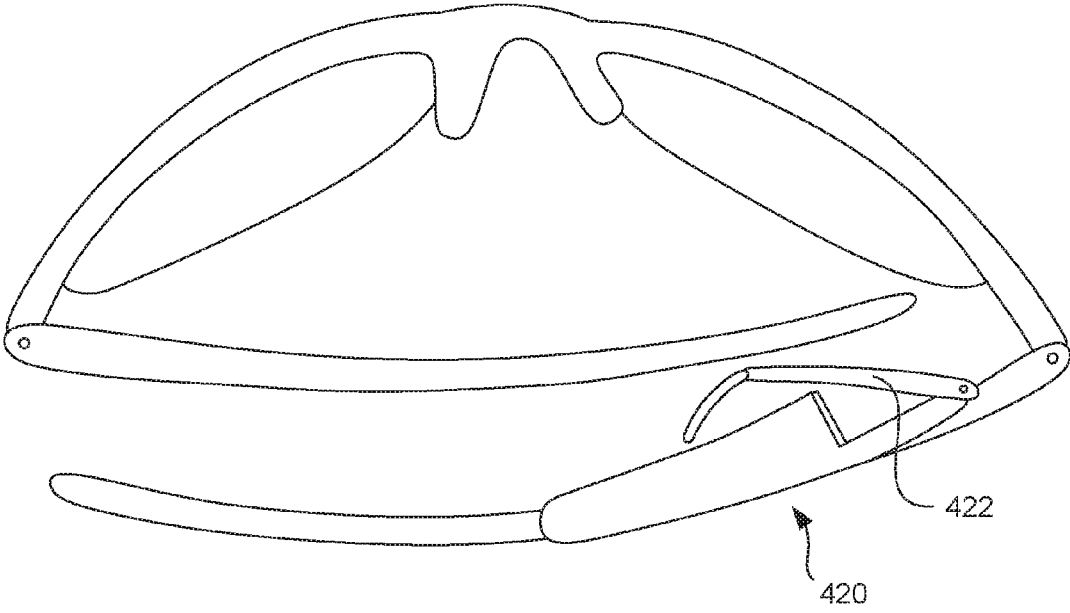

FIG. 9

ELECTRONIC EYEWEAR AND DISPLAY**CROSS-REFERENCE TO RELATED APPLICATIONS**

The patent application claims priority to U.S. Patent Application No. 61/792,702, entitled, "Electronic Eyewear and Display," filed Mar. 15, 2013, and U.S. Patent Application No. 61/868,676, entitled, "Electronic Eyewear and Display," filed Aug. 22, 2013, both of which are hereby incorporated herein by reference.

FIELD OF THE DESCRIBED EMBODIMENTS

The described embodiments relate generally to electronic eyewear. More particularly, the described embodiments relate to apparatuses, methods and systems for electronic eyewear that includes a display.

BACKGROUND OF THE INVENTION

It is desirable to have methods, systems and apparatuses for providing electronic eyewear that includes a display.

SUMMARY OF THE INVENTION

In one embodiment, an eyewear apparatus includes a display and a frame. The frame includes a side region that includes an extendable arm. The first end of the extendable arm is attached to the frame and a second end of the extendable arm is attached to the display. The side region includes a cavity, where the extendable arm is adapted to retract back. The extendable arm is further adapted to extend out of the cavity and orient the display to be visually observable by a user of the eyewear apparatus.

In another embodiment, an eyewear apparatus includes a concave reflective and an image source. The image source and the concave reflective surface are oriented to enable a user of the eyewear apparatus to view at least an image from the image source as reflected by the concave reflective surface. In one embodiment, the apparatus includes a lens. The concave reflective surface can be integral with the lens. In another embodiment, the apparatus includes a frame. The concave reflective surface can be in the frame. In another embodiment, the frame includes an extendable arm with a first end and a second end. The first end of the extendable arm is configured to be attached to the frame, and the concave reflective surface is configured to be in the vicinity of the second end. Yet another embodiment includes a lens, an additional image source and an additional concave reflective surface, with the additional source and surface being located at opposite sides of the lens. In one embodiment, the eyewear apparatus is in a module.

Other aspects and advantages of the present invention will become apparent from the following detailed description, which, when taken in conjunction with the accompanying drawings, illustrates by way of example the principles of the invention.

BRIEF DESCRIPTION OF THE DRAWINGS

FIG. 1 shows an electronic eyewear that includes a display, according to an embodiment of the invention.

FIG. 2 shows an alternate view of the electronic eyewear of FIG. 1 that includes the display, according to an embodiment of the invention.

FIG. 3 shows the electronic eyewear of FIGS. 1 and 2, wherein the display is at least partially embedded in a temple region of the electronic eyewear, according to an embodiment of the invention.

FIG. 4 shows an electronic eyewear that includes a display, according to an embodiment of the invention.

FIG. 5 shows an alternate view of the electronic eyewear of FIG. 4 that includes the display, according to an embodiment of the invention.

FIG. 6 shows the electronic eyewear of FIGS. 4 and 5, wherein the display is at least partially embedded in a temple region of the electronic eyewear, according to an embodiment of the invention.

FIG. 7 shows an embodiment of an electronic display apparatus for eyewear that includes a concave reflective surface and an image source.

FIG. 8A-8B show different embodiments of an electronic display apparatus for eyewear that includes an extendable arm that is extended.

FIG. 9 shows an embodiment of an electronic display apparatus for eyewear that includes an extendable arm that is retracted.

Same numerals in FIGS. 1-9 are assigned to similar elements in all the figures. Embodiments of the invention are discussed below with reference to FIGS. 1-9. However, those skilled in the art will readily appreciate that the detailed description given herein with respect to these figures is for explanatory purposes as the invention extends beyond these limited embodiments.

DETAILED DESCRIPTION OF THE INVENTION

One embodiment includes an electronic eyewear with a display. The electronic eyewear includes a side region and a front region, and the display can be attached to the side region of the eyewear. In one embodiment, the side region includes a temple region. In another embodiment, the eyewear includes a front region with two sides, and two side regions, one connected to each side of the front region.

In different embodiments, an electronic eyewear can be, for example, a pair of sunglasses, fit-over glasses, prescription glasses, safety glasses, goggles, such as ski goggles, and "frame-less" glasses; an auxiliary frame, and a swim mask; and an electronic apparatus wearable by a user in the vicinity of one or both eyes of the user.

In one embodiment, the electronic eyewear includes at least a front region and a side region. The front region is configured to be in front of the user wearing the electronic eyewear. The side region is configured to be on a side of the user wearing the electronic eyewear.

FIG. 1 shows a block diagram of an electronic eyewear according to one embodiment. For this embodiment, the electronic eyewear includes a frame **100** that includes a pair of temples or arms **102, 104**; and a lens holder adaptable to hold one or more lenses (for example, lenses **160, 162**). In one embodiment, a "frame-less" glasses can be an eyewear with two lenses connected by a bridge, with each lens also connected to an arm or temple.

While two lenses **160, 162** are depicted in FIG. 1, the electronic eyewear can include a single eye-piece forming goggles rather than the standard lenses of glasses. As an example, the lens could be a single wrap-around lens. For an embodiment, the frame **100** is adaptable to hold one or more lenses, such as, lenses **160, 162**.

In another embodiment, the frame **100** includes a connecting piece between lenses such as in a pair of frame-less glasses.

As shown, the frame **100** further includes a display **110**. For example, at least one of the arms **102**, **104** includes a region **120** that includes an extendable arm **125**, wherein a first end of the extendable arm **125** is attached to the temple region **120** and a second end of the extendable arm **125** is attached to the display **110**.

An embodiment includes an eyewear apparatus. The eyewear apparatus includes a frame, and a display. For an embodiment, the frame includes a side region that includes an extendable arm, wherein a first end of the extendable arm is attached to the frame and a second end of the extendable arm is attached to the display.

For an embodiment, a temple region **120** or a side region of the eyewear includes a cavity, wherein the extendable arm **125** is adapted to retract back to the cavity, and can fit within or substantially within the cavity. For an embodiment, the extendable arm **125** is further adapted to extend out of the cavity and orient the display **110** to be visually observable by a user of the eyewear apparatus. For an embodiment, the extendable arm **125** includes at least one rotatable joint, allowing adjustment of a distance between the display **110** and the one or more lenses **160**, **162**.

For an embodiment, the extendable arm **125** includes at least one rotatable joint, allowing adjustment of an orientation of the display **110** relative to the one or more lenses. For an embodiment, the extendable arm **125** includes at least one rotatable joint, allowing adjustment of an orientation of a viewing plane of the display **110** relative to a frontal plane of the one or more lenses, or relative to a frontal plane of the lens holder. For an embodiment, a retracted state of the electronic eyewear includes the extendable arm **125** retracted into the cavity. For an embodiment, a user-activated action causes the extendable arm **125** to pop out, or to extend out, of the cavity. In one embodiment, the extendable arm **125** can be user-adjusted.

For an embodiment, an extendable arm includes two or more pieces, wherein at least two of the pieces are connected at endpoints, wherein the pieces rotatably adjust at the endpoints. For an embodiment, a first piece rotatably connected to the temple region and a last piece is rotatably connected to the display.

For an embodiment, at least one conductor extends through the extendable arm, electronically connecting the display to a controller location within the eyewear.

For an embodiment, the display **110** includes an LCD display.

For an embodiment, the display **110** includes a projection screen. For an embodiment, the apparatus further includes a projector for displaying images on the projection screen.

For an embodiment, the apparatus further includes light-guide optical element operative to display images on the display.

In one embodiment, the different attributes of the different embodiments of the electronic eyewear can be programmable, such as via switches on the corresponding eyewear, or wirelessly via a remote control, or both. Examples of switches on a frame can include a knob, a slider or a small dial on the corresponding frame to program the electronic eyewear.

FIG. 2 shows an alternate view of the electronic eyewear of FIG. 1 that includes the display, according to an embodiment.

FIG. 3 shows the electronic eyewear of FIGS. 1 and 2, wherein the display is at least partially embedded in, or concealed within, a temple region of the electronic eyewear, according to an embodiment.

FIG. 4 shows an electronic eyewear that includes a display, according to an embodiment.

FIG. 5 shows an alternate view of the electronic eyewear of FIG. 4 that includes the display, according to an embodiment.

FIG. 6 shows the electronic eyewear of FIGS. 4 and 5, wherein the display is at least partially embedded in, or concealed within, a temple region of the electronic eyewear, according to an embodiment.

In one embodiment, the electronic eyewear includes at least one focusing lens between the display and an eye of the wearer. The focusing lens helps focus the image from the display to the eye. The focusing lens can be a Fresnel lens. In one embodiment, the electronic eyewear includes at least one lens as in a lens of a pair of glasses; and the focusing lens is built into the at least one lens.

In one embodiment, electronics for the electronic eyewear is in an eyewear frame. In another embodiment, the electronic eyewear with the corresponding electronics, such as the control circuitry, can be in a secondary frame, which is attachable to a primary frame via different mechanisms, such as magnets. The primary frame can include a pair of prescription lenses. To illustrate, there can be a housing or a chassis holding prescription lenses, with the electronic eyewear provided on the outside, such as via a clip-on.

In one embodiment, the electronic eyewear with the corresponding control circuitry and power source can be in a fit-over frame that can fit over another frame.

In one embodiment, the electronic eyewear can include prescription lenses providing focal correction, such as bifocal, tri-focal, prism, etc.

In one embodiment, the electronic eyewear is rechargeable or includes power sources, such as a battery, to allow the eyewear to perform its operation over a duration of time, such as a few hours.

One embodiment further includes monitoring if the user is wearing the eyewear. In one embodiment, the electronic eyewear includes a time sensor that times at least one of how long and how frequently the user wears the eyewear. For an embodiment, the time sensor is attached to, integral with, or being a part of the electronic eyewear. For an embodiment, information related to the monitoring/sensing of the eyewear is stored, such as in the eyewear. For an embodiment, after stored, the monitoring information can be later retrieved, for example, by a doctor or physician to allow the physician to determine or gauge the compliance (e.g. duration of time of wearing the eyewear) by the user with a therapy suggested by the doctor or physician. The retrieval can be performed through a wire connection (e.g. via an electrical connector at the eyewear) or wirelessly (e.g. via an infrared sensor or a wireless transceiver at the eyewear).

In one embodiment, a motion detector is used as the "being worn" sensor. A threshold can be set, such that if the amount of motion exceeds the threshold, the eyewear is assumed to be worn. The motion detector can, for example, be achieved by a mechanical means or an accelerometer.

In another embodiment, the "being worn" sensor includes two thermal sensors. One sensor can be at approximately the middle or close to one end of an arm, such as in a region that touches the head of the user wearing the eyewear. The other sensor can be at the other end of the arm, such as close to lens holder of the eyewear. If the temperature differential between the two sensors is beyond a certain preset value, the

eyewear would be assumed to be worn. The differential is presumed to be caused by a person wearing the eyewear.

In yet another embodiment, the eyewear includes at least one hinge, and the hinge is configured to allow an arm of the eyewear to be foldable. In one embodiment, the “being worn” sensor includes a stress sensor at the hinge of the arm. The assumption is that when the eyewear is worn, the hinge is typically slightly stretched because typically, the width of the head of the user is slightly wider than the width between the arms when the two arms are in the extended positions. If the value of the stress sensor is beyond a certain preset value, the eyewear would be assumed to be worn.

In a further embodiment, the “being worn” sensor can be a switch. For example, at the hinge between an arm and its corresponding lens holder, there is a switch. When that temple is fully extended outwards, the switch is turned on. The switch can be a pin. When the temple is fully extended outwards, the pin is pressed. When both arms are fully extended outwards, in one embodiment, the eyewear would be assumed to be worn by the user.

In one embodiment, the electronic eyewear includes one or more lenses based on liquid crystal lens technologies.

In one embodiment, the electronic eyewear may be secured from the back with a functional strap, such as a lanyard. In one embodiment, the lanyard may contain the electronics, such as control circuitry and power source, of the electronic eyewear. This can provide additional ergonomic qualities and securing for active users.

FIG. 7 shows an embodiment of an electronic display apparatus for eyewear **200** includes a concave reflective surface **202** and an image source **204**. The image source **204** could include a liquid crystal display (LCD) or a light emitting diode type of display (LEDD), with a circuit board having electronics attached. The image source **204** and the concave reflective surface **202** can be configured to be oriented to enable a user of the electronic display apparatus to view at least an image from the image source **204** as reflected by the concave reflective surface **202**.

In one embodiment, the electronic display apparatus for eyewear is adapted or configured for an electronic eyewear.

In one embodiment, the electronic display apparatus for eyewear includes at least one lens. In one embodiment, at least a portion of a concave reflective surface is integrated with the at least one lens. For example, the at least one lens can include a transparent portion and the at least a portion of the concave reflective surface. In another embodiment, such as for a pair of sunglasses, the at least one lens can include a near-transparent portion and the at least a portion of the concave reflective surface. In yet another embodiment, the at least one lens can include a substantially non-reflective portion (which could be transparent or near-transparent) and the at least a portion of the concave reflective surface.

At least a portion of the concave reflective surface and at least a portion of the image source can be located on opposite sides of the at least one lens. For example, the at least a portion of the concave reflective surface is at an upper portion of the at least one lens, while the at least a portion of the image source is at the vicinity around a lower portion of the at least one lens. In another example, at least a portion of the concave reflective surface and at least a portion of the image source are located in the vicinity on a same side of the at least one lens.

In yet another embodiment, the at least one lens is configured to be located between the image source and the concave reflective surface, and is configured to enable a user of the eyewear apparatus to view at least an image from the image source as reflected by the concave reflective surface.

In one embodiment, the electronic display apparatus for eyewear includes a frame, and at least a portion of the concave reflective surface is in or integral with the frame. The apparatus also can include at least one lens. In one embodiment, at least a portion of the concave reflective surface, or at least a portion of the image source, or both, are at the frame. The at least a portion of the concave reflective surface, and the at least a portion of the image source both can be located in the vicinity of the opposite sides of the at least one lens. For example, the at least a portion of the concave mirror is at the frame, adjacent to an upper portion of the at least one lens; and the at least a portion of the image source is at the frame, adjacent to a lower portion of the at least one lens.

FIGS. **8a** and **8b** show different embodiments of an electronic display apparatus for eyewear including an extendable arm that are extended. For example, FIG. **8a** shows an embodiment **220** of an electronic display apparatus for eyewear that includes an extendable arm **222**. The electronic display apparatus for eyewear can also include a frame with a side region, wherein at least a portion of an image source is in the side region of the frame. The extendable arm has a first end and a second end. The first end of the arm **222** is configured to be attached to the frame, and a concave reflective surface **224** is configured to be attached in the vicinity of the second end. In one embodiment, the frame includes one or more lenses, such as in a pair of glasses.

In FIG. **8a**, the extendable arm **222** is configured to be on the inside of the frame, and when extended, the concave reflective surface **224** is positioned behind at least one of the lenses, in between the at least one lenses and the user wearing the frame.

In the embodiment shown in FIG. **8a**, the extendable arm **222** includes a pivot **226**. The pivot **226** can be configured to be behind the pivot **228** of the frame when the frame **228** is worn.

In another embodiment, an extendable arm is on the outside of a frame, and when extended, the concave reflective surface is in front of at least one of the lenses. In this embodiment, the at least one of the lenses is located in between the concave reflective surface and the user when the extendable arm is extended.

In one embodiment, the electronic display apparatus for eyewear includes more than one image source. In another embodiment, the electronic display apparatus for eyewear includes more than one concave reflective surfaces. For example, each image source can be configured to operate with a corresponding concave reflective surface. For each image source and the corresponding concave reflective surface, at least a portion of the image source and at least a portion of its corresponding concave reflective surface can be located in the vicinity of the opposite sides of at least one lens.

FIG. **8b** shows an embodiment **320** of an electronic display apparatus for eyewear including an extendable arm **322** that is extended. FIG. **9** shows an embodiment, **420** of an electronic display apparatus for eyewear including an extendable arm **422** that is retracted.

In one embodiment, an electronic display apparatus for eyewear is configured to be in a module. FIGS. **8A** and **8B** show such an example. In the example shown in FIG. **8a**, the module **220** can include an image source, such as a LCD **230**, with circuit boards, **232** and **234**, and a battery **236**. In another embodiment, the module can be integrated into a frame, such as the frame of a pair of glasses.

The various embodiments, implementations and features of the invention noted above can be combined in various ways or used separately. Those skilled in the art will understand from the description that the invention can be equally applied to or used in other various different settings with respect to various combinations, embodiments, implementations or features provided in the description herein.

Numerous specific details are set forth in order to provide a thorough understanding of the present invention. However, it will become obvious to those skilled in the art that the invention may be practiced without these specific details. The description and representation herein are the common meanings used by those experienced or skilled in the art to most effectively convey the substance of their work to others skilled in the art. In other instances, well-known methods, procedures, components, and circuitry have not been described in detail to avoid unnecessarily obscuring aspects of the present invention.

Also, in this specification, reference to "one embodiment" or "an embodiment" means that a particular feature, structure, or characteristic described in connection with the embodiment can be included in at least one embodiment of the invention. The appearances of the phrase "in one embodiment" in various places in the specification are not necessarily all referring to the same embodiment, nor are separate or alternative embodiments mutually exclusive of other embodiments. Further, the order of blocks in process flowcharts or diagrams representing one or more embodiments of the invention do not inherently indicate any particular order nor imply any limitations in the invention.

Other embodiments of the invention will be apparent to those skilled in the art from a consideration of this specification or practice of the invention disclosed herein. It is intended that the specification and examples be considered as exemplary only, with the true scope and spirit of the invention being indicated by the following claims.

What is claimed:

- 1. An eyewear apparatus, comprising:
 - a frame with a front and at least a side; and
 - a display;
 wherein the side couples to an extendable arm,
 wherein the side comprises a cavity,
 wherein the extendable arm comprises at least a first piece and a second piece, with one end of the first piece

connected to the side via a first hinge, with the display connected to the second piece, the two pieces being connected by at least a rotatable joint to at least allow adjustment of an orientation of the display relative to the front of the frame,

wherein the extendable arm is adapted to retract back to the cavity, and when retracted, the extendable arm fits substantially in the cavity and the display is also substantially in the cavity,

wherein the extendable arm is further adapted to extend out of the cavity and orient the display to be visually observable by a user of the eyewear apparatus,

wherein the front is connected to the side via a second hinge,

wherein the first hinge includes a first rotating axis, wherein the second hinge includes a second rotating axis, and

wherein the first rotating axis of the first hinge is configured not to be collinear with the second rotating axis of the second hinge.

2. The apparatus of claim 1, wherein the extendable arm is caused to extend out of the cavity by a user-activated action, allowing the extendable arm to be user-adjusted.

3. The apparatus of claim 1, wherein at least one conductor extends through the extendable arm, electrically connecting at least an electrical component in the display to a controller located within the frame.

4. The apparatus of claim 1, wherein the display comprises a screen, and wherein the apparatus comprises a projector for at least displaying images on the screen.

5. The apparatus of claim 1, wherein the apparatus further comprises at least a light-guide optical element operative to enable at least viewing of images on the display.

6. An eyewear apparatus as recited in claim 5, wherein the extendable arm cannot telescope.

7. An eyewear apparatus as recited in claim 5, wherein the display comprises a screen.

8. An eyewear apparatus as recited in claim 7, wherein the apparatus comprises a projector for at least displaying the images on the screen.

* * * * *